



Terra Kaffe

# Welcome to your Demi

English

# Welcome to the future of coffee brewing.

Thank you for your purchase of Demi,  
the first step in elevating your coffee routine.

# Table of Contents

Safe Handling of Demi	04
What's in The Box?	07
For Best Operation and Maintenance	10
Preparing for First Use	12
Making Coffee on Demi	13
Using the Selector Dial	14
Drink Settings Menu	15
General Setting Menu	16
Cleaning Your Demi	18
Regular Maintenance	24
Trouble Shooting	25
Specifications	27
Warranty	29

# Safe Handling of Demi

## IMPORTANT SAFEGUARDS



When using electrical appliances, one must abide by the following safety precautions:

1. Read all instructions before use and save for future reference.
2. Remove all packaging material and labels/stickers before using the Demi for the first time.
3. To protect against fire, electric shock, and injury, do not immerse cord, plugs, or appliance in water or other liquids.
4. Do not block ventilation holes on the top or sides of the machine.
5. Close supervision is necessary when the appliance is used near children. This appliance is not intended for use by persons (including children) with reduced physical, sensory, or mental capabilities, or lack of experience or knowledge unless they have been given supervision or instruction concerning the use of the appliance by a person responsible for their safety.
6. Fully unwind power cord before use and plug power cord into the machine first, then your home's power outlet before use.
7. Unplug from the outlet when not in use and before cleaning. Allow to cool before putting on or taking off parts and before cleaning the appliance.
8. Do not operate any appliance with a damaged cord or plug or after the appliance malfunctions or has been damaged in any manner.
9. Do not pull out the plug by the cord or touch it with wet hands.
10. Do not use outdoors.
11. Do not keep the machine at temperatures below 40 degrees Fahrenheit - frost may damage the machine.
12. This appliance is equipped with a power cord having a grounding wire with a grounding plug. The appliance must be grounded using a 3-hole, properly grounded outlet. In the event of an electrical short circuit, grounding reduces the risk of electric shock.

13. If the power outlet is a standard 2-prong wall outlet, it is the personal responsibility of the user and obligation to have the outlet replaced with a properly grounded 3-prong wall outlet.
14. Do not, under any circumstances, cut or remove the third (ground) prong from the power cord or use an adaptor.
15. Consult a qualified electrician if the grounding instructions are not completely understood or if doubt exists as to whether the appliance is properly grounded.
16. Never allow water to come in contact with any of the electrical parts of the machine — danger of short circuit and burning.
17. Do not let the cord hang over the edge of tables or counters or touch hot surfaces.
18. Do not place the appliance on or near a hot gas or electric burner.
19. Do not place hands or other body parts near the spout during the machine's routine brewing or cleaning process to avoid any potential burns or other injuries.
20. Always turn off the appliance before disconnecting it from the wall outlet.
21. Do not use the appliance for any reason other than intended use.
22. Check power specifications to be sure that the voltage indicated on the nameplate corresponds with your power specifications.
23. Never use boiling water to fill the water tank. Only use room-temperature water.
24. Keep your hands and the cord away from hot surfaces of the appliance during operation.
25. In case of failure, problems, or suspected malfunction resulting from a machine failure, immediately remove the plug from the socket. Never attempt to operate a faulty machine. If problems persist, contact Terra Kaffe immediately.
26. In case of fire, use carbon dioxide (CO<sub>2</sub>) extinguishers. Do not use water or dry powder extinguishers.
27. Do not touch hot surfaces. Use handles or knobs.
28. Do not place objects on top of the machine.

29. The use of accessory attachments not recommended by the appliance manufacturer may result in fire, electric shock or injury to persons.
30. Do not use appliance for other than intended use.
31. Any servicing, other than cleaning and basic user maintenance, should be performed by authorized service personnel. To reduce the risk of fire or electric shock, do not disassemble the machine. There are no parts inside the machine serviceable by the user. Repair should be done by authorized service personnel only.
32. Disassembling or unscrewing any parts of the machine will result in a termination of the company's warranty agreement. It is strictly forbidden to tamper with the internal parts of the machine.
33. Avoid contacting moving parts. Do not attempt to defeat any safety interlock mechanisms.

Do not hesitate to contact our Customer Experience Team for assistance at [contact@terrakaffe.com](mailto:contact@terrakaffe.com)

# What's in The Box?

## Machine

---

1. Display screen
2. Coffee/hot water spout
3. Drip tray\*
4. Waste bin panel
5. Coffee bean hopper
6. Coffee bean hopper lid
7. Power switch
8. Selector dial
9. Waste bin\*
10. Water tank\*

\*This part is not dishwasher safe.

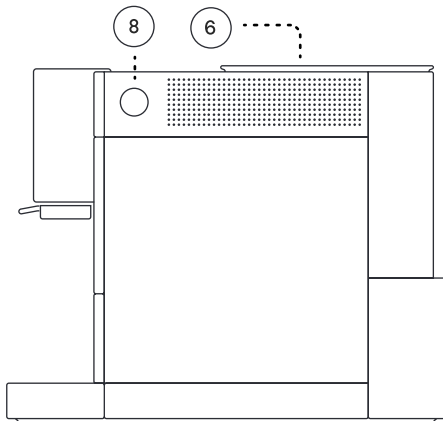
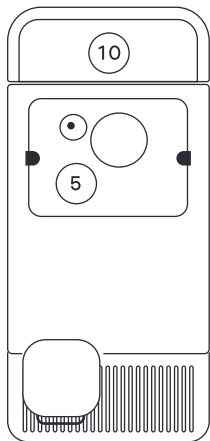
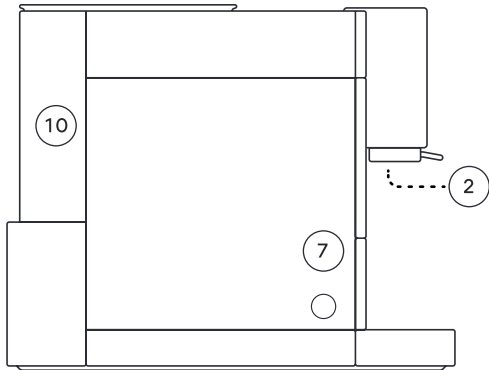
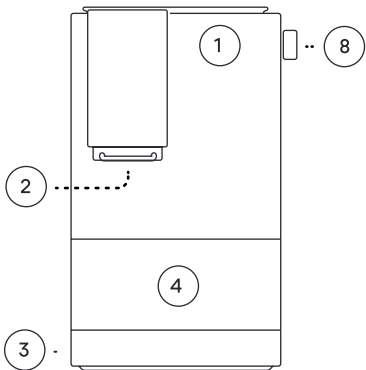



**Please note:** For safety and maintenance, after 1 hour of non-use, the machine will enter standby mode. After 6 hours in standby mode, the machine will enter sleep mode. Before going to sleep, and if the machine has brewed a drink since the wake cycle, it will perform a rinse before going to sleep. Otherwise, it will go right to sleep. In standby mode, the machine will lower the temperature of the internal heating component to conserve energy.

# For Best Operation and Maintenance

1. Choose a safe, level surface where there will be no danger of overturning the appliance or being injured.
2. Choose a location that is out of reach of children or others who shouldn't independently operate the Demi.
3. Provide a minimum distance of 1.5 inches from all sides of the machine in order to provide airflow for vents.
4. While waking or putting the machine to sleep, we suggest placing an empty glass under the dispensing spout.
5. Carefully follow all cleaning prompts and Terra Kaffe's cleaning and maintenance instructions.
6. Never clean with scrubbing powders or harsh cleaners. Simply use a soft damp cloth with water.
7. Do not use oily or flavored coffee beans.
8. Do not adjust anything in the Calibration menu without express guidance from the Terra Kaffe Customer Experience Team

# Sleep and Wake States

## Best Practices

1. For safety and maintenance, after 1 hour of non-use, the machine will enter Standby mode. After 6 hours in standby mode, the machine will enter sleep mode. Before going to sleep, and if the machine has brewed a drink since the wake cycle, it will perform a rinse before going to sleep. Otherwise, it will go right to sleep without a rinse. In standby mode, the machine will lower the temperature of the internal heating component to conserve energy.
2. To manually turn your machine to sleep, simply press and hold for 3 or more seconds on the selector dial until the machine goes to sleep. Do not use the power switch on the lower left side of the machine to put your machine to sleep, as this will not allow the machine's clock to keep time, and it will also bypass an important rinse cycle.
3. Turning your Demi off using the left side power switch is only necessary when the machine will not be used for an extended period of time. This switch should be used only if your Demi has been put to sleep first.
4. To wake up your Demi, press and hold the selector dial until your Demi wakes up.
5. You can also schedule your Demi to turn on and prepare to brew by using the auto scheduling feature. To access this feature, use your selector dial to navigate: MENU > SETTINGS > AUTO > WAKE > SET TIME.

# Preparing for First Use

1. Unpack the machine.
2. Plug the machine into an outlet.
3. If using a water filter, remove the water filter from its protective packaging and hold upside down under running water for thirty seconds.
4. Once fully saturated, the filter can be installed into the water tank in the back of the machine.
5. Add coffee beans to the coffee bean hopper.
6. Turn on Demi's power button on the left side of the machine.
7. Follow the steps shown on the Quick Start Guide.
8. During the start up cycle, please note that short spurts of hot water will come out from the nozzle, which poses a risk of scalding. Do not place your hands near the spout during the rinse cycle.

## For best function and taste:

1. Fill the water tank with only fresh, still, room-temperature water.
2. Fill the coffee hopper with only fresh, room-temperature, non-oily, unflavored whole coffee beans. Never put anything other than whole coffee beans in the coffee bean hopper, as anything else will damage the machine.
3. We recommend discarding the first two drinks your Demi brews.

Once you've followed the steps above, you're ready to brew your first drink. Simply place a cup under the spout, and select whichever drink you'd like to brew with the selector dial. After clicking the dial, grinding and brewing will begin.



Please note: Coffee beans are used to factory test Demi, and it is completely normal for there to be traces of coffee grounds.

## Making Coffee on Demi

Use the selector dial to display your drink on the front panel. Press the selector dial to start brewing. When a drink is tapped, the brewing screen is displayed, and the drink begins brewing immediately. You can add an extra shot to your drink while the coffee beans are grinding by rotating the selector dial clockwise.

Once brewing, drinks can be canceled at any time by pressing and holding the selector dial. If canceling a drink during the grinding process, all coffee grounds in the brew unit will be used for the next drink.

## Choosing Coffee Beans

1. Freshly roasted, quality coffee beans will provide the best flavor and extraction.
2. Terra Kaffe offers a variety of coffee beans on the TK website.
3. In general, TK recommends freshly roasted coffee that lists on the bag a "Roasted On" date, not an expiration date, a "Best Before" date, or a "Use By" date.
4. TK recommends consuming coffee beans within 60 days of the "Roasted On" date.

# Using the Selector Dial

The Selector Dial is the main point of interaction with the machine. Use it to select your drinks and make your adjustments in the settings.

1. Pressing and holding the selector dial when your machine is asleep will wake the machine up
2. Pressing and holding the selector dial from the main screen when your machine is awake will put your Demi to sleep
3. Rotating the selector dial allows you to rotate between options on the main menu or other menus
4. Pressing the selector dial selects whichever text is currently on the screen
5. When in sub-menus, pressing and holding the selector dial for 2 or more seconds will bring you back to the main menu
6. While brewing a drink, rotating the selector dial counterclockwise will allow you to add additional shots to your brew

# Drink Settings Menu

Below is a tree diagram of the Drink Settings Menu and the default settings for each variable.

Refer to this diagram to find the setting you wish to adjust.

## Edit Drink Menu

### ↳ Espresso

- ↳ Shots: 1
- ↳ Strength: High (11g)
- ↳ Shot Volume: 50ml
- Brewing Temp: 96 °C
- ↳ Back

### ↳ Lungo

- ↳ Shots: 1
- ↳ Strength: High (11g)
- ↳ Shot Volume: 50ml
- Brewing Temp: 96 °C
- ↳ Back

### ↳ Americano

- ↳ Shots: 1
- ↳ Strength: High (11g)
- ↳ Shot Volume: 50ml
- Brewing Temp: 96 °C
- ↳ Back

### ↳ Drip

- ↳ Shots: 1
- ↳ Strength: High (11g)
- ↳ Shot Volume: 50ml
- Brewing Temp: 96 °C

### ↳ Hot Water

- ↳ Volume: 200 ml
- ↳ Brewing Temp: 94 °C
- ↳ Back

# General Settings Menu

Below is a tree diagram of the General Settings Menu.  
Refer to this diagram to find the setting you wish to adjust.

## Menu

### ↳ Cleaning

- ↳ Rinse: flush fresh clean water through the spout
- ↳ Brewer: see “Cleaning Your Demi” for brewer cleaning instructions
- ↳ Descale: see “Cleaning Your Demi” for descaling instructions
- ↳ Drain: this will allow you to drain all fluids from your machine for shipping or storage
- ↳ Back

### ↳ Settings

#### ↳ Clock

- ↳ Set Time
- ↳ Display
- ↳ Back

#### ↳ Units

- ↳ Volume: metric or imperial settings
- ↳ Time: 12 hr or 24 hr clock
- ↳ Hardness: water hardness in your area, on a scale of very soft to very hard. This will affect how often you’ll be prompted to descale and how often you’ll need to change your filter.
- ↳ Back

- ↳ Auto: This will allow you to program your Demi to wake up, warm, and ready to brew at a specific time

#### ↳ Wake

- ↳ Set Time
- ↳ Off

- ↳ Sleep
- ↳ Back
- ↳ Sound
  - ↳ On
  - ↳ Off

- ↳ Light
  - ↳ Low
  - ↳ Med
  - ↳ High

- ↳ Calibrate\*

\*For manufacturing and customer support use only. Changing these settings without guidance from Terra Kaffe's Customer Experience Team will void warranty.

- ↳ Reset  
(This resets your drink settings to the factory settings)
- ↳ Confirm
- ↳ Cancel
- ↳ Back

- ↳ Info

- ↳ Shots: how many shots your Demi has brewed
- ↳ Status: This will tell you how many shots until you need to run each process listed within
  - ↳ Brewer
  - ↳ Descale
  - ↳ Filter: once you've changed the filter, please navigate to FILTER > CONFIRM to reset the counter
  - ↳ Back

- ↳ Back

- ↳ Sleep
  - ↳ Confirm
  - ↳ Cancel
- ↳ Back

# Cleaning Your Demi

Demi will notify you when it is time to run a cleaning function. When maintenance is due, Demi illuminates one of four dot-matrix segments—each indicating a specific cleaning task, as shown below.

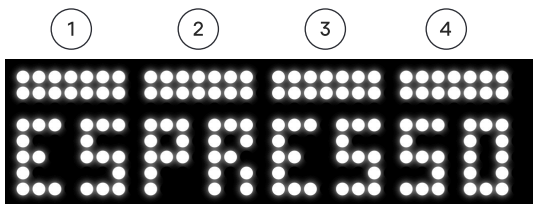

- 1 Brewer Cleaning
- 2 Descaling
- 3 Change Water Filter
- 4 Remove and Rinse Brew Unit

Do not use sharp objects or harsh chemical products (solvents) for cleaning. Use a soft, dampened cloth to clean the exterior of the machine. For internal cleaning cycles, use cleaning agents specifically designed for espresso machines.

## Brewer Cleaning

Running a brewer cleaning cycle eliminates coffee residue and oils from the Demi's brew unit, optimizing extraction. This simple and automated cleaning process maintains the quality and consistency of brewed drinks, even after thousands of brews.

Use only automatic espresso machine-formulated brewer cleaning product - using unsuitable brewer cleaner and/or performing brewer cleaning incorrectly may result in faults not covered by the manufacturer's warranty.

1. Confirm that the cleaning product is a brewer cleaning product.
2. Ensure the water tank is full.
3. Ensure the drip tray is empty.
4. Remove the brew unit and fill the circular brew basket with brewer cleaning agent.
5. Reinsert the brew unit.
6. Follow the prompts on the screen

To access automated brewer cleaning when the prompt is not displayed, from the Homepage of the touch screen, select Menu > Cleaning > Brewer.



**WARNING:** Failure to run cleaning and descaling cycles when prompted may lead to machine malfunction and may void your warranty.

## Descaling

Descaling Demi is a simple, automatic cleaning process that removes calcium deposits and limescale that occur naturally from the water used to brew coffee. Based on the hardness setting you select in the water hardness menu, refer to the cleaning screen on the machine for how frequently you'll need to descale. Use only automatic espresso machine-formulated descaling product; using an unsuitable descaler and/or performing descaling incorrectly may result in faults not covered by the manufacturer's warranty. In case of accidental ingestion, refer to the manufacturer's warning on the cleaning agent packaging.

To descale:

1. Confirm that the cleaning product is a descaling product.
2. Remove and empty the water tank.
3. Ensure the drip tray is empty.
4. Remove the water filter.
5. Fill the water tank with warm water and add the appropriate amount of descaler.
6. Mix the solution and wait for it to dissolve.
7. Reinsert the water tank.
8. Follow the instructions on the display.
  - a. Cleaning >
  - b. Empty Drip Tray + Press Dial >
  - c. Cleaning >
  - d. Empty Drip Tray + Press Dial >
  - e. Rinse + Add Clean Water + Press Dial >
  - f. Cleaning >
  - g. Empty Drip Tray + Press Dial >
  - h. Espresso (home screen)

- !** **Note:** Place a large container under the spout to catch the water that will dispense during descaling. Cover delicate surfaces to prevent damage from descaling chemicals.

To access automated descaling when the prompt is not displayed, select Menu > Cleaning > Descale with the selector dial.

## Water Filter

The machine will alert you when it is time to replace the water filter. The alert frequency is based on the shot count. Replacing the water filter will keep your machine brewing fresh coffee!

To change the water filter:

1. Remove and empty the water tank.
2. Hold the water tank and pull up on the water filter.
3. Hold the new water filter upside down under running water for 30 seconds.
4. Install the new water filter by placing in position and pressing down. Ensure the water filter is fully seated.
5. Fill the water tank.
6. Reinsert the water tank.
7. Follow the instructions on the display.

For extra cleanliness, it is also recommended to hand wash the water tank at the same interval as the water filter change.

Once you've successfully changed your water filter, you can reset the counter by navigating as follows:  
**MENU > CLEANING > FILTER > CONFIRM.**

## Removing and Rinsing the Brew Unit

Your Demi will let you know when it's time to remove and rinse the brew unit. Doing this keeps the brew unit able to move smoothly and brew to perfection.

- 1 . Gently remove the brew unit panel on the right side.
- 2 . Press the lever on the brew unit to disengage from Demi.
- 3 . Slide the brew unit out, and rinse it under cool water, keeping it upright.
- 4 . Note that mechanical lubricant may be present on the brew unit, which is normal and should remain.
- 5 . Don't use hot water or soap.
- 6 . Let the brew unit dry, then gently slide back into the Demi until you hear it click into place.
- 7 . Put the right side panel back into position.

## Rinsing The Spout

Demi will automatically rinse the spout when the machine is turned on, or put in and out of sleep mode.

To access automated rinsing when the machine is already on, from the Homepage, select Menu > Cleaning > Rinse.



Please note: Short spurts of hot water will come out from the nozzle during the cleaning cycles, which poses a risk of scalding. Do not place your hands near the spout during the rinse cycle.

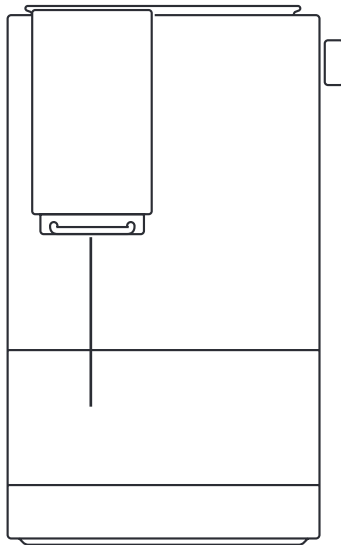

# Regular Maintenance

While your Demi comes equipped with the above self-cleaning functions, attention must be paid to the machine's cleanliness regularly to ensure smooth operation and longevity.

Before and after use, use this quick checklist to ensure your Demi lives a long, happy life:

1. Remove and rinse the brew unit weekly.
2. Wipe down all surfaces to remove any liquids or coffee.
3. Inspect the small crevices under the spout and brush with a soft bristle to dislodge any grime.
4. Check the drip tray to ensure no coffee grounds have begun piling up in excess.
5. Ensure the telescoping spout handle can move smoothly.
6. We recommend checking your coffee beans before adding them to the hopper to ensure no debris (eg, rocks, twigs) is present.
7. Clean the water tank.
8. Dump and rinse the waste bin. Coffee grounds left to sit for extended periods can result in bacteria growth.



**Please Note:** The water tank, drip tray, waste bin, brew unit and hopper cover are not dishwasher safe. Please handwash and allow to air dry.

# Troubleshooting

The majority of issues with brewing on Demi can be remedied by following the instructions on the screen.

## Power

If your machine fails to power on, first ensure that the outlet is functioning. If the outlet is not functioning, check the circuit breaker or fuse box for any tripped circuits or blown fuses. If there is an issue with your circuit breaker or fuse box, remove other appliances from the circuit.

## Water Supply

If you are experiencing an “Push water tank in” alert after replacing your water filter, ensure you have followed the installation instructions on pre-soaking your water filter accordingly. If you have, then run the filter under running water to remove any trapped air from the filter. Replace and continue brewing.

## Drip Tray

If struggling to install the drip tray, pull the drip tray out of the machine and check for coffee grounds inside the drip tray slot. If the drip tray is leaking, ensure the drip tray is installed all the way and is not stuck or blocked by coffee grounds. Ensure the machine is on a level surface.

If issues persist, run a descale cleaning cycle before contacting Terra Kaffe.

## Brewing

If the machine is brewing clear water, check to ensure there are beans in the hopper. If the machine is still brewing clear water, run a Brewer cycle from the cleaning menu.

If the machine is brewing coffee slowly run a Clean Brew Unit cycle from the cleaning menu. If this doesn't fix the issue, increase the grind size using the grinder dial inside the hopper.

If the machine is grinding too many grounds into the drip tray, contact our Customer Experience team.

In the event that more help is needed, you can find a robust collection of help videos on our YouTube channel: [youtube.com/@terrakaffe](https://www.youtube.com/@terrakaffe). Additionally, you may contact our Customer Experience Team for troubleshooting assistance by email: [contact@terrakaffe.com](mailto:contact@terrakaffe.com) or phone: + 1-718-738-7488

Any other servicing should be performed by a certified Terra Kaffe technician.

# Specifications

Machine Dimensions*	15.55" (D) x 7.5" (W) x 12.40" (H)
Machine Weight	17 lbs
Cup Clearance	5.7"
Bean Hopper Capacity	130 g
Water Tank Capacity	1375 ml
Drip Tray Capacity	600 ml
Waste Bin Capacity	7 pucks
Power	1350W
Voltage	120 volts
Line Frequency	60Hz

\* 8" with selector dial

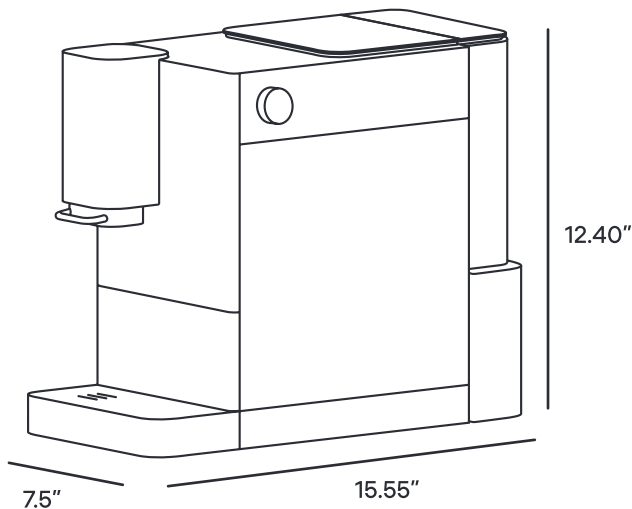

8" with selector dial

## Disposal

The symbol on the material, accessories or packaging indicates that this product must not be treated as domestic waste. Dispose of the equipment via the collection point for the recycling of scrap electrical and electronic equipment.



# Warranty

This warranty applies to all espresso machines from Terra Kaffe. Terra Kaffe warrants each product to be free from defects in material and workmanship.

The drip tray, waste bin and the water tank are not dishwasher safe.

From the delivery date as indicated by the shipper, our obligation under this warranty is to provide 1 year or 3,000 cups (whichever comes first) free parts and labor on the entire unit.

If repair is not possible at the discretion of Terra Kaffe, a refurbished unit of less usage will be provided.

Under warranty, all products in need of repair are to be shipped at Terra Kaffe's expense to an authorized Terra Kaffe service center, and Terra Kaffe will then incur the outgoing and return shipping costs.

This warranty shall apply only if the product is used in accordance with the manual directions that accompany it, and on an Alternating Current (AC) circuit. This warranty is in lieu of all other warranties and representations, expressed or implied, and all other obligations or liabilities on our part. We do not authorize any other person or company to assume for us any liability in connection with the sale or use of our product.

Within the warranty period, Terra Kaffe may, at its sole discretion, either repair the product with new or remanufactured parts or replace the product entirely with a comparable model at equal or less usage at no additional charge to the consumer. The machine's cup counter determines usage. Terra Kaffe may replace defective parts with any serviceable remanufactured parts that meet the performance specifications of new parts for any applicable product.

This warranty shall not apply to any product that has been repaired or altered outside our factory, nor shall it apply to any product that has been subjected to misuse, negligence, or accidents. This warranty covers only products purchased through Terra Kaffe or one of Terra Kaffe's authorized resellers or distributors. This warranty does not cover any products purchased through an auction, a private seller (such as eBay, Facebook Marketplace,...etc.) or a non-authorized online reseller.

This warranty does not cover consequential or incidental damages. (Please note, however, that some jurisdictions do not allow the exclusion or limitation of consequential or incidental damages, so this limitation may not apply to you.) The terms "incidental damages" refer to the loss of the original purchaser's time, loss of the use of the machine or other costs relating to the care and custody of the machine. The term "consequential damages" refers to the cost of repairing or replacing other property that is damaged when this machine does not work properly.

This warranty is only valid for products purchased, located, and used in United States jurisdiction and shall not extend to any product used outside the United States. The United States includes the fifty United States and the District of Columbia only, not including any other U.S. territories, commonwealths, possessions, or protectorates.

For any inquiries about your product, see the contact information below:

U.S. Residents: Please contact us at [contact@terrakaffe.com](mailto:contact@terrakaffe.com).

The above warranty is in lieu of all other express warranties and representations. All implied warranties are limited to the applicable warranty period set forth above. This limitation does not apply if you enter into an extended warranty with Terra Kaffe. No other warranties, express or implied, are made by Terra Kaffe or are authorized to be made on behalf of Terra Kaffe by any retailer, agent, distributor or other party with respect to any product to any consumer or other party. Terra Kaffe does not authorize any other person or company to assume for it any liability in connection with the sale or use of its appliance.

Any servicing, other than cleaning and basic user maintenance, should be performed by authorized service personnel. To reduce the risk of fire or electric shock, do not disassemble the machine. Disassembling or unscrewing any parts of the machine will result in a termination of the company's warranty agreement. There are no parts inside the machine serviceable by the user. Repair should be done by authorized service personnel only. It is strictly forbidden to tamper with the internal parts of the machine.



**Intertek**

Need troubleshooting help?



Scan this code with your phone's camera,  
or visit <https://support.terrakaffe.com/>

Designed in New York.